



Soil
cultivation



Planting



Harvesting



Storage



Grading

DEWULF R3060/R4060
SELF-PROPELLED
2-ROW
SIEVING HARVESTER

dewulf
enjoy growing

INDISPUTABLE CRAFTSMANSHIP, FOR OVER A QUARTER CENTURY

The Dewulf R3060 two-row sieving harvester has often been imitated but never equalled. In 1989 Dewulf reached a milestone with the introduction of the first self-propelled three-wheel offset potato harvester with gooseneck steering. Dewulf was awarded the Golden Spike for this clever concept in 1990, during the Agribex exhibition in Brussels, Belgium. The unique harvester distinguished itself from all others with unprecedented manoeuvrability and the ability to continue harvesting where others were stopped in their tracks. How? It's simple really: the R3060 doesn't drive

over the ground being harvested. As such, the harvester can even harvest in very extreme conditions without damaging potato ridges. Thanks to the sophisticated weight distribution, the machine provides unparalleled stability, both in the field and on the road. Since its introduction we have carefully continued to refine and improve the machine without compromising what makes it so unique. In 2014 Dewulf presented the fifth generation of its market-leading two-row self-propelled sieving harvesters. This is the result of having taken to heart all the feedback from professional

users who work with the machines in real world conditions, as is quickly apparent to those who examine them closely.



1989: R3000



1999: R3000 Mega



2014: R3060 GII

1994: R3000S



2006: R3060 GI



QUICK CHANGE SYSTEM (QCS)

As standard, the R3060 is equipped with a QCS potato kit with two diaboloes, cutting discs and harvesting shares. This makes it possible to quickly switch between different optional harvesting kits: 75/90 cm diaboloes or half diaboloes, driven cutting discs, onion kit or carrot kit. It only takes 15 minutes to make the swap. The harvesting unit can be optionally equipped with DAS (Dewulf Automatic Steering) and ADC (Automatic Depth Control).



HAULM TOPPER

The R3060 is standard equipped with a durable Hardox steel haulm topper as well as ADC (Automatic Depth Control) and Side-Shift. Two drag shoes at the bottom, each operating a lifting cylinder, keep the flails at a precise height above the ridges. Because the haulm topper is suspended on the front wheel frame it achieves perfect pulverisation in the curves. The depth can be set automatically from the cab. An extra-wide haulm topper is also available as an option, to meet special requirements.



SYNCRO FLOW

With Syncro Flow from Dewulf the speed of the sieving webs is synchronised to match the driving speed. Via the control unit the sieving chains can be slowed down or sped up by a certain percentage relative to the driving speed.



KEYPAD

A user-friendly keypad is provided on the sorting platform to allow the inspection workers to control up to eight functions, including the acoustic signal, speed of the discharge belt, slope of hedgehog belt 2 and more.

9 VERSIONS THANKS TO MODULAR CONSTRUCTION

Conditions differ from one country or region to the next, so the specific requirements for a harvester vary too. The R3060 is available in nine different versions to accommodate all those specific circumstances. Dewulf offers a wide range of options to provide customised solutions. Rather have a discharge elevator than a bunker? Then the RA4060 is your best choice.



RS3060

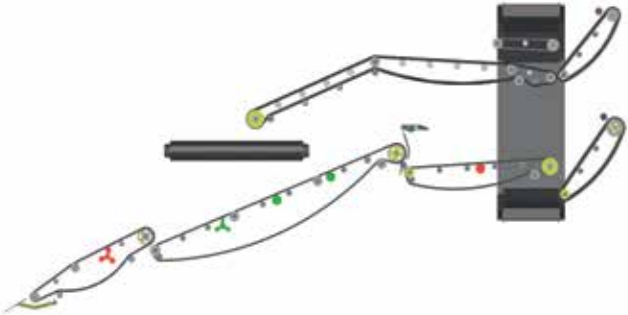

RA3060

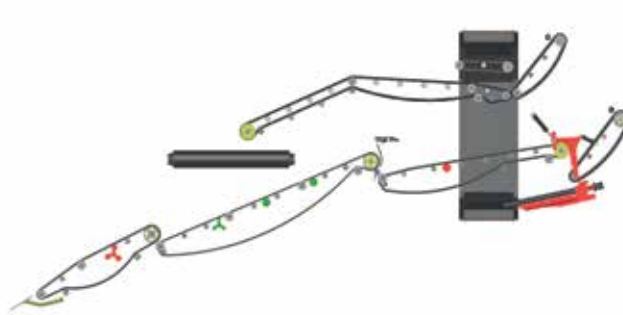

p.6

RA3060 with 2 haulm rollers



p.6

RF3060

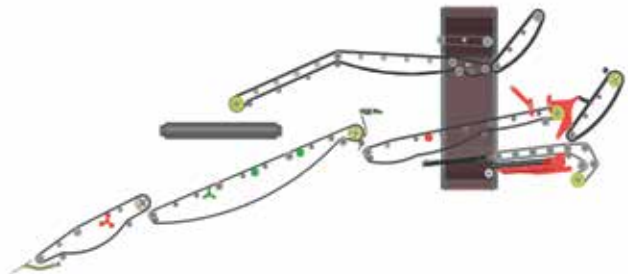

p.8

RQ3060

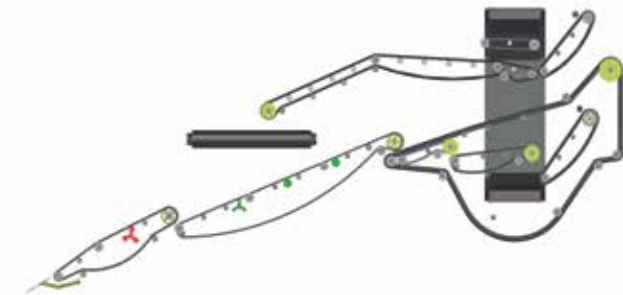

p.10

RQA3060

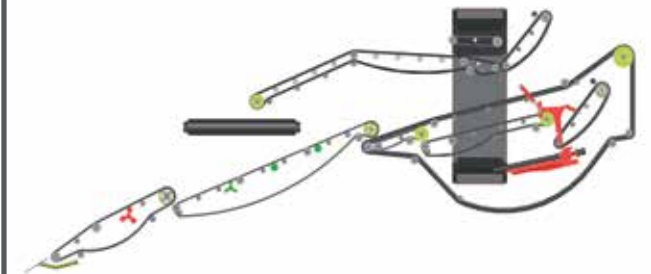

p.10

RJA3060

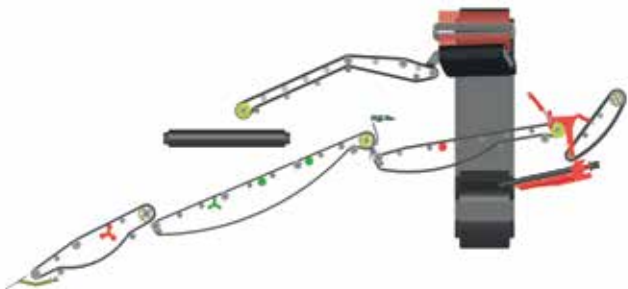

p.8

RCE3060

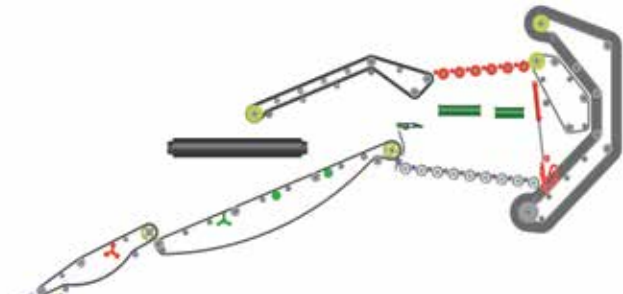

p.12

RCA3060

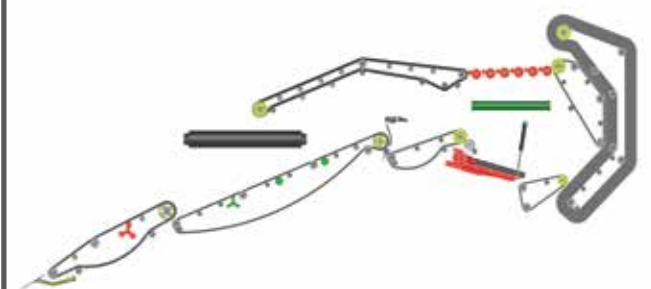

p.12

RA3060

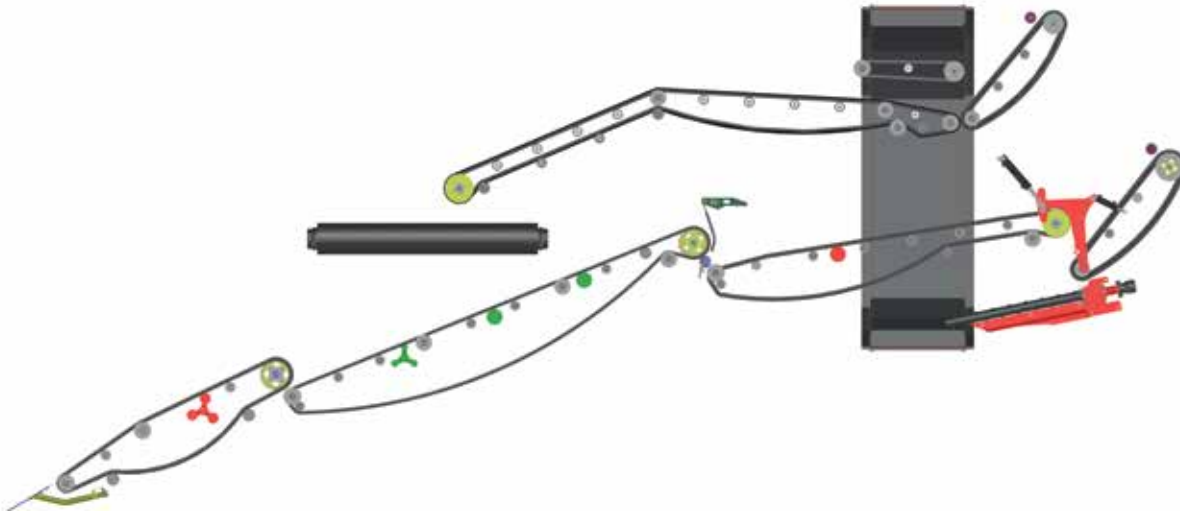

RA3060 with 2 haulm rollers

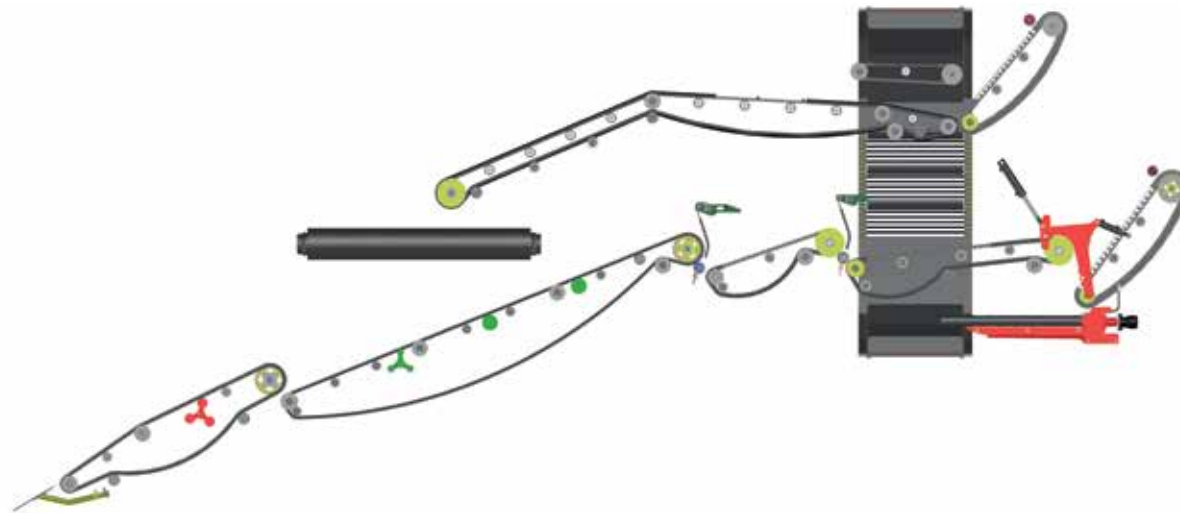

HARVESTING UNIT	RA3060	RA3060 (2)
Width 1500 mm	•	•
Width 1650 mm	o	o
APC (Automatic Pressure Control)	•	•
Syncro Flow	•	•
DAS (Dewulf Automatic Steering)	o	o
ADC (Automatic Depth Control)	o	o

SIEVING WEBS	RA3060	RA3060 (2)
Length sieving conveyor 1 [mm]	2065	2065
Length sieving conveyor 2 [mm]	3820	3820
Length sieving conveyor 3 [mm]	3030	1280
Length sieving conveyor 4 [mm]	-	1940

HAULM REMOVAL	RA3060	RA3060 (2)
Haulm chopper with ADC	•	•
Haulm roller(s)	1	2

CLEANING AND SORTING	RA3060	RA3060 (2)
Agitator in sieving conveyor 1	o	o
Agitator in sieving web 2	•	•
Agitator in sieving web 3	o	-
Hedgehog unit 2	•	•
Cleaning module	•	•
Hedgehog unit 2	•	•
Sorting unit in the discharge conveyor	o	o

DIMENSIONS	RA3060	RA3060 (2)
Total length [mm]	12 800	12 800
Total width [mm]	3500	3500
Total height [mm]	4000	4000
Weight from [kg]	19 750	19 750

• : standard o : optional - : not possible

4 CLEANING MODULES



In wet conditions, harvested potatoes tend to stick together in large clods of soil. The R3060 first transports the potato flow over a wide hedgehog unit where these large clods are broken down into smaller ones before they reach the cleaning module. This boosts the cleaning capacity and perfectly distributes the potato flow over the entire width of the cleaning module. The parallelogram construction allows the incline angle to be adjusted to up to 12.5°, while the angle of the hedgehog unit remains unchanged. The parallelogram construction between the sieving conveyor 3, hedgehog unit and cleaning module also ensures that all the drop heights remain constant, regardless of the position of the cleaning module.

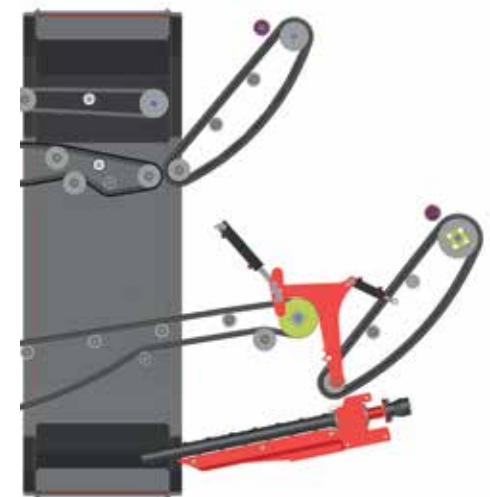
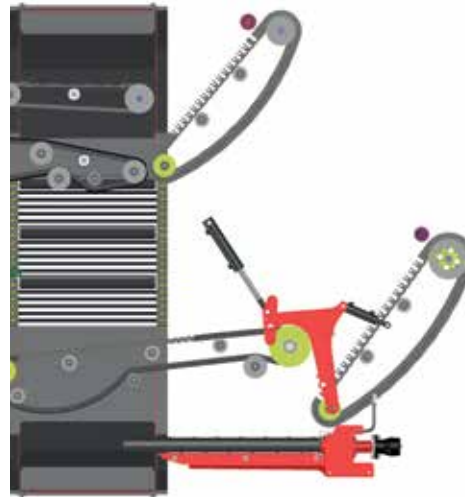

SIEVING MODULE

If you want additional sieving capacity in your R3060, the sieving module is the solution. This module can also be fitted with an eccentric agitator for even greater sieving capacity.



AXIAL MODULE

The axial module has 18 speed-adjustable rollers. The varying length of the axial rollers ensures that the lifting elevator is filled across its full width, providing exceptionally potato-friendly transport.



EASYSKLEAN MODULE

The EasyClean module is the perfect choice for those who work in fields with moderate soil conditions or in cloddy and stony conditions. This module, with its transverse roller pairs, is exceptionally efficient in a wide range of applications, from extremely dry to very wet.



FLEXSTAR MODULE

The Flexstar module is used for harvesting carrots. This cleaning module is equipped with eight individual hydraulically driven shafts with star rollers. The gap between the star rollers can be hydraulically adjusted from 0 to 30 mm. The Flexstar module is equipped with an anti-blocking system and an automatic cleaning function.

RF3060

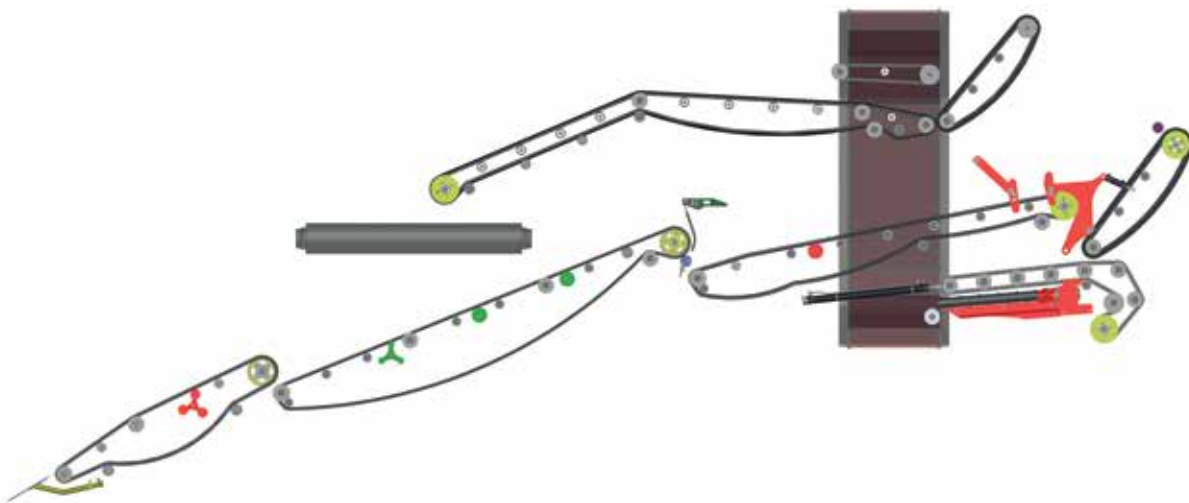

RJA3060

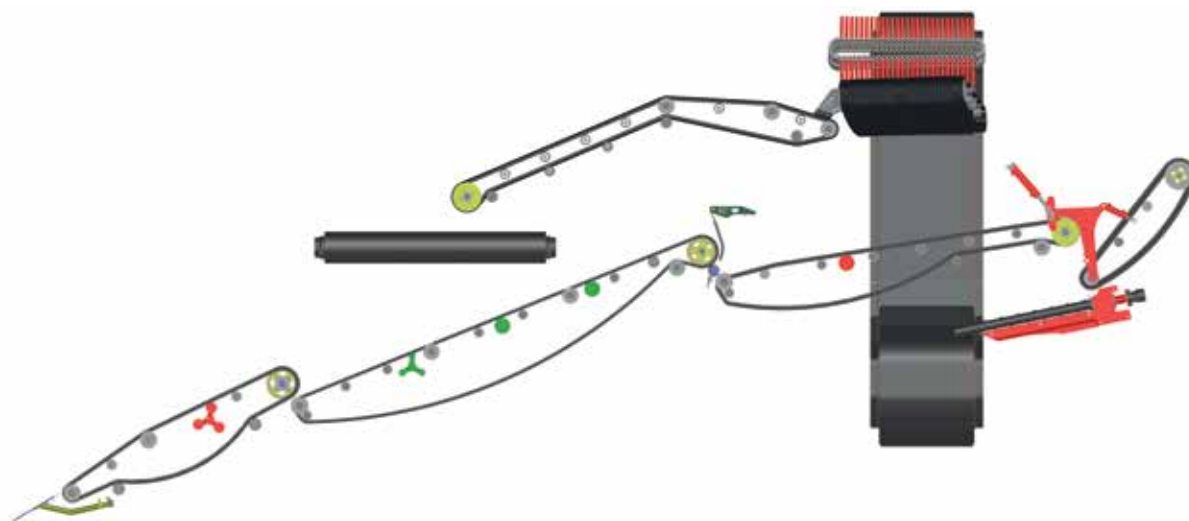

HARVESTING UNIT	RF3060	RJA3060
Width 1500 mm	•	•
Width 1650 mm	o	o
APC (Automatic Pressure Control)	•	•
Syncro Flow	•	•
DAS (Dewulf Automatic Steering)	o	o
ADC (Automatic Depth Control)	o	o
SIEVING CONVEYORS		
Length sieving conveyor 1 [mm]	2065	2065
Length sieving conveyor 2 [mm]	3820	3820
Length sieving conveyor 3 [mm]	3250	3030
HAULM REMOVAL		
Haulm topper with ADC	•	•
Haulm roller	•	•
CLEANING & SORTING		
Agitator in sieving conveyor 1	o	o
3 agitators in sieving conveyor 2	•	•
Agitator in sieving conveyor 3	o	o
Hedgehog unit 1	•	•
Flexyclean®	•	-
Cleaning module	-	•
Hedgehog unit 2	•	•
2 deflecting rollers	-	•
2 x 2 rows of rubber studs	-	o
Sorting unit	o	-
DIMENSIONS		
Total length [mm]	13 500	12 800
Total width [mm]	3500	3500
Total height [mm]	4000	4000
Weight from [kg]	20 250	19 750

• : standard o : optional - : not possible

RF3060



Thanks to Flexyclean® you are extremely flexible with regard to cleaning. A variable bypass system gives you control over cleaning of the product flow, from 0 to 100%. That way you always achieve the desired cleaning of the product based on the conditions you are facing. Flexyclean® is only available in combination with axial rollers.

RJA3060



J-ELEVATOR

The 900 mm wide J-elevator provides product-friendly transport to the discharge conveyor. Its speed and direction of rotation are adjustable from the cabin. The elevator is equipped with an anti-blocking system to prevent blockages.



DEFLECTING ROLLERS

The RJA3060 is standard equipped with two deflecting rollers above the upper flat hedgehog belt. The deflecting rollers are best suited for harvesting carrots and onions. The height and speed of the rollers can be adjusted from the sorting platform.



DEFLECTING BELT

You can also opt for a 2 x 2 row deflecting belt with adjustable speed. The position of the deflecting belt frame is continuously adjustable to any angle above the hedgehog unit, for effective removal of stones and clods.

RQ3060

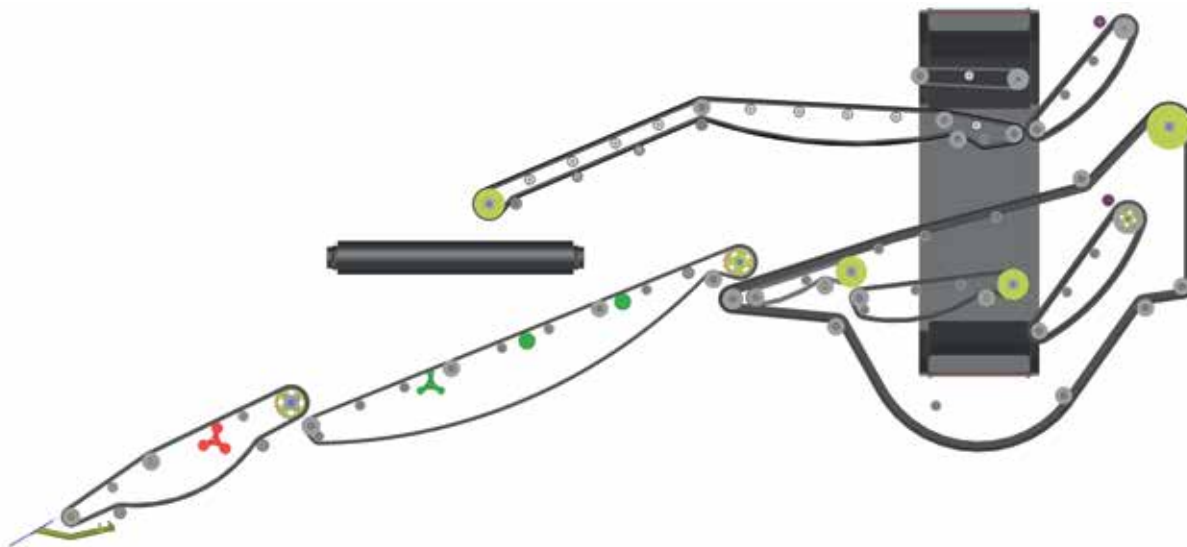

RQA3060

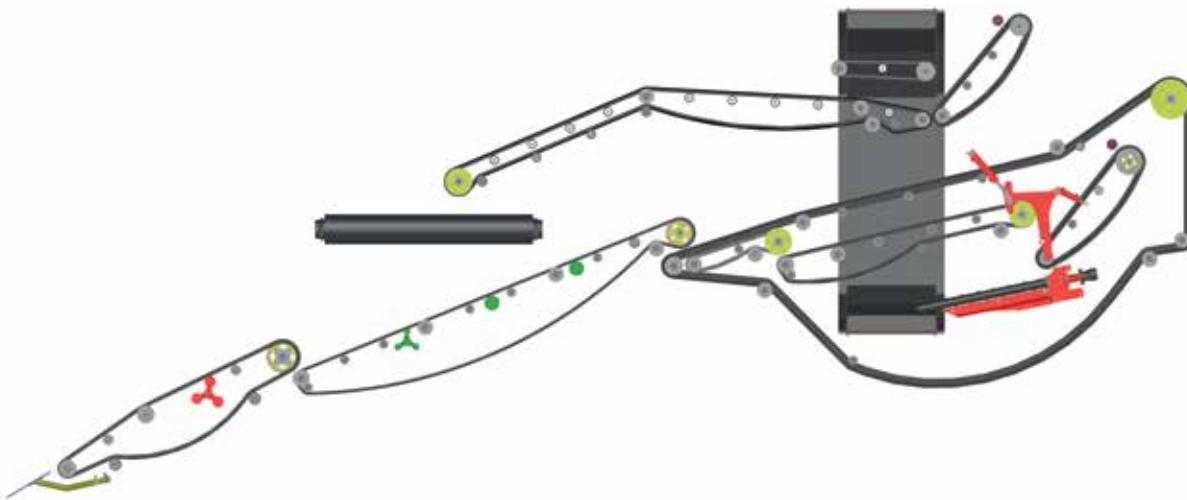

HARVESTING UNIT	RQ3060	RQA3060
Width 1500 mm	•	•
Width 1650 mm	o	o
APC (Automatic Pressure Control)	•	•
Syncro Flow	•	•
DAS (Dewulf Automatic Steering)	o	o
ADC (Automatic Depth Control)	o	o
SIEVING CONVEYORS		
Length sieving conveyor 1 [mm]	2065	2065
Length sieving conveyor 2 [mm]	3820	3820
Length sieving conveyor 3 [mm]	1000	1000
Length sieving conveyor 4 [mm]	1452	2345
HAULM REMOVAL		
Haulm topper with ADC	•	•
Haulm conveyor	•	•
CLEANING		
Agitator in sieving conveyor 1	o	o
3 agitators in sieving conveyor 2	•	•
Hedgehog unit 1	•	•
Cleaning module	-	•
Hedgehog unit 2	•	•
DIMENSIONS		
Total length [mm]	12600	13 900
Total width [mm]	3500	3500
Total height [mm]	4000	4000
Weight from [kg]	19250	20 500

• : standard o : optional - : not possible



HAULM CONVEYOR

The RQ3060 and RQA3060 are equipped with a haulm conveyor to separate haulm from the product flow. The three haulm spring sets are each hydraulically adjustable in height. The extra, fully enclosed bar web ensures smooth separation of haulm and product. This keeps dropheights to a minimum, resulting in maximum quality.



RCA3060

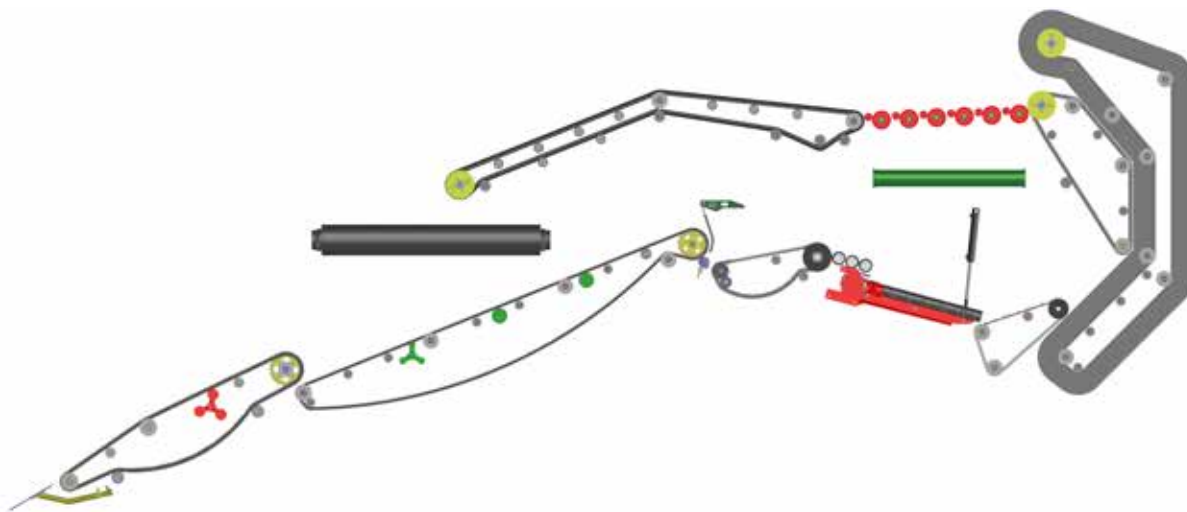

RCE3060

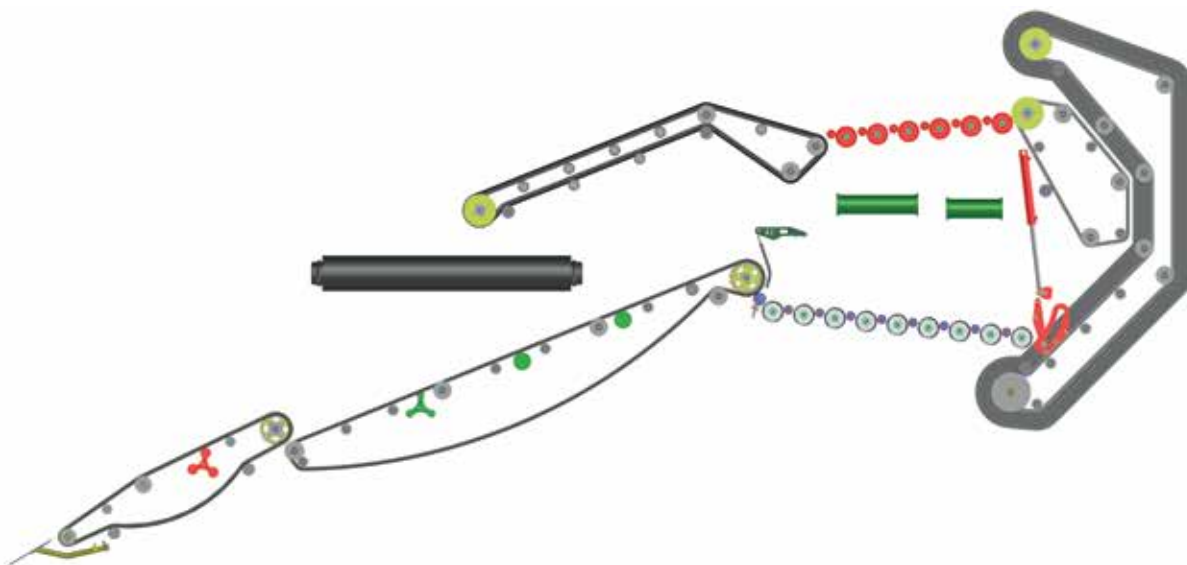

HARVESTING UNIT	RCA3060	RCE3060
Width 1500 mm	•	•
Width 1650 mm	o	o
APC (Automatic Pressure Control)	•	•
Syncro Flow	•	•
DAS (Dewulf Automatic Steering)	o	o
ADC (Automatic Depth Control)	o	o
SIEVING CONVEYORS		
Length sieving conveyor 1 [mm]	2065	2065
Length sieving conveyor 2 [mm]	3820	3820
Length sieving conveyor 3 [mm]	930	-
Length sieving conveyor 4 [mm]	795	-
HAULM REMOVAL		
Haulm topper with ADC	•	•
Haulm roller	•	•
CLEANING		
Agitator in sieving web 1	o	o
3 agitators in sieving conveyor 2	•	•
Axial module	•	-
Easyclean module	-	•
Easyclean unit 3 rollers in discharge conveyor	o	o
Easyclean unit 6 rollers in discharge conveyor	o	o
DIMENSIONS		
Total length [mm]	12 800	11 900
Total width [mm]	3500	3500
Total height [mm]	4000	4000
Weight from [kg]	21 500	19 750

• : standard o : optional - : not possible



C-ELEVATOR

The 1600 mm wide C-elevator provides product-friendly transport to the discharge conveyor. Its speed and direction of rotation are adjustable from the cabin. This lifting elevator is also equipped with a boost function to prevent blockages. As an option, the outer web can be fitted with a cloth to prevent the product from sticking.



AXIAL MODULE RCA3060

The axial module in the RCA3060 has 18 rollers, the speed and angle (-20° to +5°) of which can be adjusted from the cabin. The module is equipped with an anti-blocking system and a scraper that prevents build-ups above the gearbox of the axial module. To ensure smooth product flow smooth rollers have been fitted between sieving web 3 and the axial module.



EASYCLEAN MODULE RCE3060

As standard, the RCE3060 is equipped with an Easyclean module consisting of 8 smooth rollers (4 + 4 adjustable in height, direction of rotation and speed) alternating with spiral rollers. The Easyclean module is the perfect choice for those who work in fields with moderate soil conditions or in cloddy and stony conditions. This module with transverse roller pairs is exceptionally efficient in a wide range of applications, from extremely dry to very wet.



EASYCLEAN UNIT IN DISCHARGE CONVEYOR

The discharge conveyor can optionally be equipped with an Easyclean unit consisting of three smooth rollers alternating with deformable spiral rollers. The waste is removed from the machine by means of a waste belt. If more intensive cleaning may be required, you can opt for two Easyclean units (3 + 3 adjustable in height, direction of rotation and speed) in the discharge conveyor with associated waste belt.





RA4060

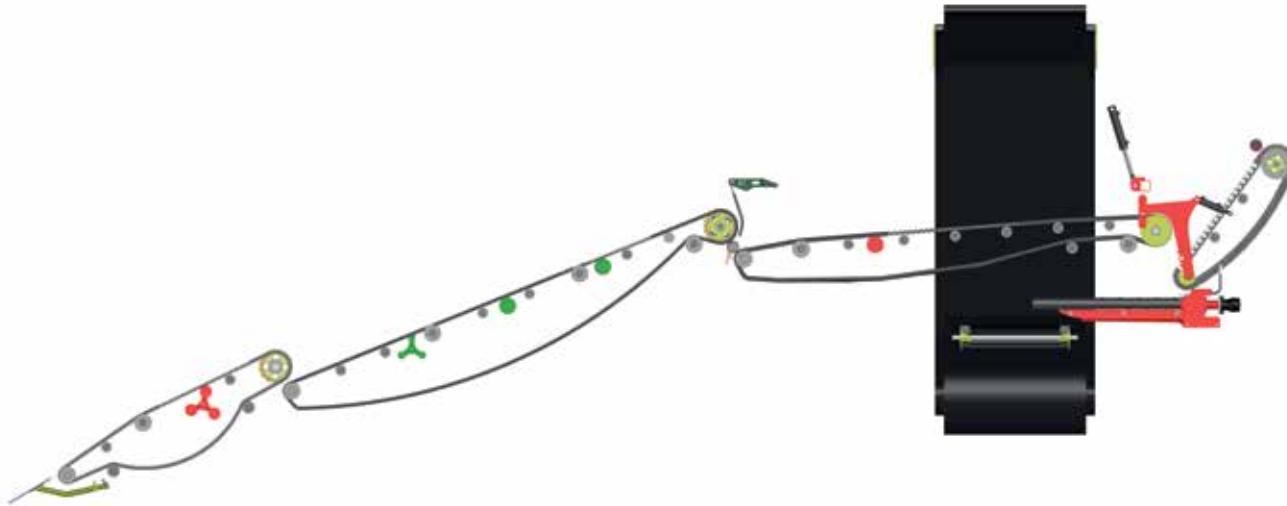

VIEW OF PRODUCT FLOW

The RA4060 offers you all the advantages of the R3060 but then with a discharge elevator instead of the bunker. The harvester offers an excellent view of the complete product flow thanks to its open construction. Thanks to the sliding cabing you have direct view of the digger web.



3-PIECE DISCHARGE ELEVATOR

After the axial module, the product first flows over a cross web for low dropheight. The 1200 mm wide discharge elevator is fitted with flights. The three-part discharge elevator can reach deep into the vehicle and thus keep the dropheight to a minimum. The discharge elevator can also place the crop between the ridges to open up the field.

HARVESTING UNIT	RA4060
Width 1500 mm	•
Width 1650 mm	o
APC (Automatic Pressure Control)	•
Syncro Flow	•
DAS (Dewulf Automatic Steering)	o
ADC (Automatic Depth Control)	o
SIEVING CONVEYORS	
Length sieving conveyor 1 [mm]	1800
Length sieving conveyor 2 [mm]	3500
Length sieving conveyor 3 [mm]	3030
HAULM REMOVAL	
Haulm topper with ADC	•
Haulm roller	•
CLEANING	
Agitator in sieving conveyor 1	o
3 agitators in sieving conveyor 2	•
Agitator in sieving conveyor 3	o
Hedgehog unit 1	•
Cleaning module	•
DIMENSIONS	
Total length [mm]	13 838
Total width [mm]	3500
Total height [mm]	4000
Weight from [kg]	15 000

• : standard o : optional



Dewulf has also developed Super Vision, an automatic triggering system for the cameras. When a particular event occurs, the camera image of that part of the machine is immediately displayed on a large screen.

A WORK ENVIRONMENT IN WHICH YOU FEEL AT HOME

In designing the large Claas cabin Dewulf has created a very pleasant working environment where everything revolves around the driver. Comfort and ergonomics have been taken to a new level. The cabin is centrally located behind the harvesting unit to ensure a good view of the intake. The operation – via the joystick and control-units for the harvesting and driving sections – provide the driver with a simple, comfortable way to operate the machine. All the additional control buttons are also clustered together to ensure very convenient operation. Pedals are provided for control of the rear axle steering and machine angle. In addition to the spacious working environment there is also more storage space, and a cooled frigobox can even be provided in the cabin as an option.

The product flow can be fully monitored from the cabin via six cameras and two 10-inch colour monitors. With quad-view it is possible to display up to four camera images on one monitor. For exceptional ergonomics, Dewulf has provided a bridge with control buttons that allows you to switch between the different cameras without the need to lean forward. The bridge also serves as a bracket to which various peripherals can be attached.

The driving experience with the R3060 is superb. Thanks to the Cruise Control it is possible to set the ideal harvesting speed and return to it time after time. This allows the driver to focus entirely on the harvesting process. The automatic climate control system, included as standard equipment, maintains the ideal cabin temperature for the driver regardless of weather conditions.



**WORKING WITH EASE
MEANS WORKING MORE QUICKLY**

The ergonomic joystick lies comfortably in the hand, keeping necessary hand movements to a minimum. Moreover, various harvesting adjustments can be linked to five configurable preset buttons. This enables you to change all the machine adjustments at the press of a button.



UNLOADING ON THE MOVE = MAXIMUM PRODUCTIVITY

Stopping to unload takes valuable time. That's time you often don't have, particularly since weather conditions are often so unpredictable. That's why Dewulf offers the driving unloading bunker as standard. Unloading on the move eliminates the need to continuously interrupt the harvesting process, and in many cases boosts productivity by as much as 25%. The generously sized 11 m³ bunker is mounted on the chassis for optimum stability. The moving part of the bunker reaches deep into the tipping trailer, minimising the dropheight. From the cabin you have an excellent view of the unloading process. You no longer have to concern yourself with the filling of the bunker, because it happens fully automatically and is a standard feature. That way you can concentrate fully on harvesting the potatoes.





PURE POWER. DAY IN, DAY OUT.

The Scania DC9 385A Tier IV Final (Ad Blue) engine generates a powerful 350 hp and will impress you with its smooth running and excellent fuel efficiency. More torque, lower fuel consumption and high operational reliability. On the road the engine runs at just 1300 rpm and in the field up to a maximum of 1600 rpm. With the resulting low emissions it's environmentally friendly yet more efficient than ever. Beyond this standard equipment power plant with Ad Blue, you also have the choice of upgrading to a 400 hp engine.

UNMATCHED GROUND CLEARANCE

- Standard front wheel: Mitas 2x750 380/90 R46
- Standard right-rear wheel: Mitas 2x710 380/90 R46
- Standard left-rear wheel: Michelin 1000/50 R25
- Installation of tyre or track possible, but requires conversion of the rear axle

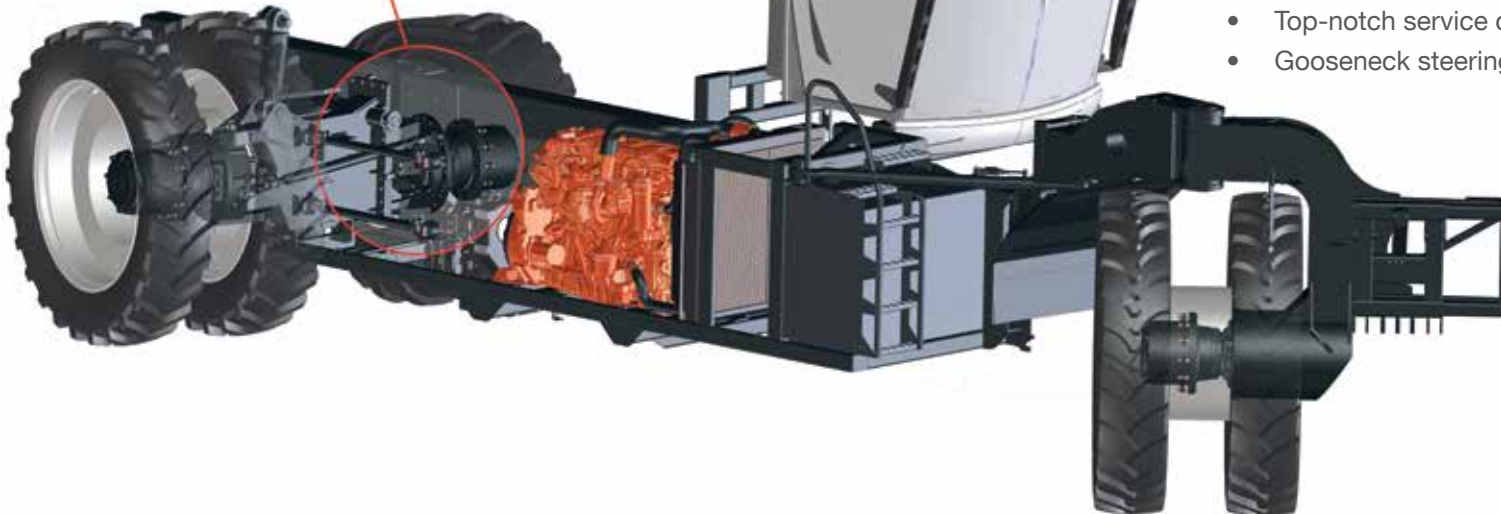

STRONG CHASSIS, STRONG ARGUMENTS

- Excellent stability
- Solid drive
- Robust rear axle with steering angle up to 20°
- Top-notch service component accessibility
- Gooseneck steering for superior manoeuvrability in the field



FLEXIBILITY FOR VARIOUS ROOT CROPS

- Potatoes
- Industrial carrots
- Parisian carrots
- Underploughed carrots
- Fresh food shop carrots
- Chicory
- Onions
- Flower bulbs
- Red beets
- Turnips
- Salsify
- ...

Moorseelsesteenweg 20
8800 Roeselare
Belgium

+32 51 20 58 71
www.dewulfgroup.com
info@dewulfgroup.com

dewulf
enjoy growing